

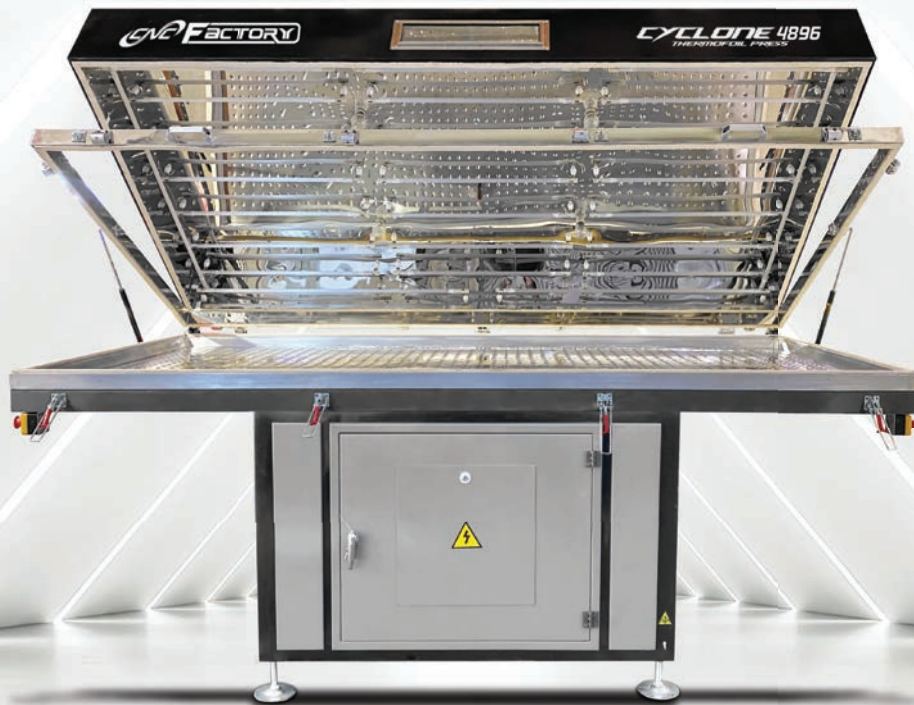

CYCLONE 4896 THERMOFOIL PRESS

FAST • FLEXIBLE • MOBILE



The Cyclone 4896 is a CNC 5th Generation, mobile thermofoil vacuum membrane press, designed for residential to commercial processing of any 3D shape.

QUICK LINKS



See the Cyclone 4896 in action on Youtube

[GET A QUOTE](#)

[SEE FINANCING OPTIONS](#)

[BUILD YOUR OWN](#)

CYCLONE 4896 AT A GLANCE

STARTS AT \$29,900

DIRECT FACTORY PRICING

Inclusions:

- 18 months parts & components warranty
- 2 years machine support
- 5 years Advanced Exchange Program

Features:

- Automated heating, vacuum forming, and cooling process
- Small footprint design
- Integrated heat sensors for accurate and even heating
- Automated vertical shell opening and closing for easy production & space saving
- Single operator
- Easy-to-operate, one-button digital PLC monitor
- 48" x 96" working table
- Interchangeable heating lamps



ABOUT US

CNC Factory, Inc., located in Southern California, USA, began over 20 years ago as a one-man business with a clear goal and dedication to helping companies embrace CNC automation.

This vision is core to our legacy as we design and manufacture high-quality, precision CNC routers and machining centers, to meet the urgent business needs of our customers. At CNC Factory, we understand since inception, that providing the fastest, most accurate and dependable CNC Machines and supporting products is only the beginning of meeting our customers' needs - we never leave them all by themselves. Together with our German, Italian and worldwide support partners, world-class machining capability is truly just the beginning.

With us at the back of (sometimes beside) our customers, their businesses have grown and we've meet their needs from quality and efficiency to the bottom line. We think beyond machine building. We also grant access to factory direct support and training before and after installation for our customers.

THE MOST IMPRESSIVE SERVICE AND
 SUPPORT WARRANTY IN THE USA



2-year Machine Support included with every Cyclone Machine



Advance Exchange Program on major components



18-Month Warranty for greater peace of mind



On-Site Support options available



Virtual Support to help guide your staff at the machine level



On-Site Installation and training options available

WEST COAST
California

EAST COAST
New Jersey

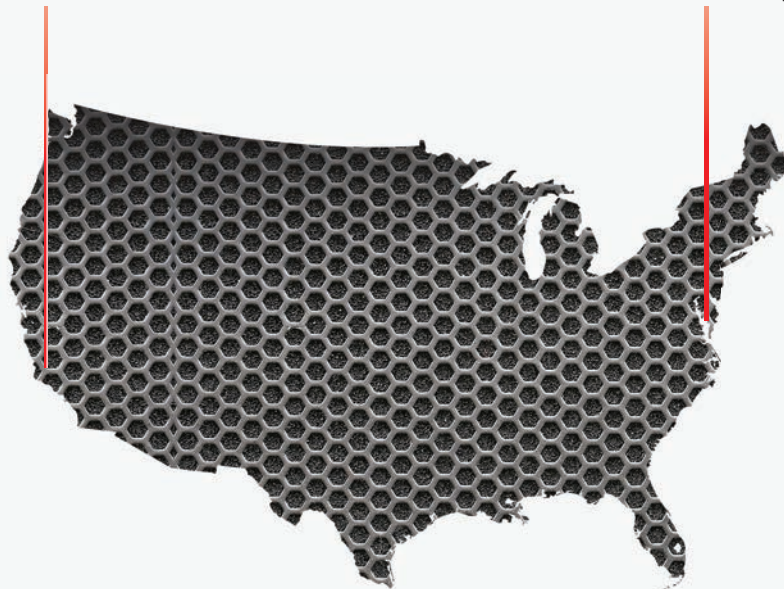

www.CNCfactory.com



714-581-5999



sales@cncfactory.com

FEATURES



SHORT-CYCLE, HIGH-YIELD 3D THERMOFOIL PRESSING

From kitchen cabinet doors, closet doors, store fixtures, and office furniture tops, the Cyclone can press virtually any 3D shape using PVC sheets, rigid sheets, PS sheets, acrylic, ABS and wood veneers.

Easy to use, a single operator can produce over 300 pieces per 8 hour shift.



AUTOMATIC PRODUCTION PROCESS

Straightforward PLC-controlled automated heating, vacuum forming & cooling— all with a press of a button.

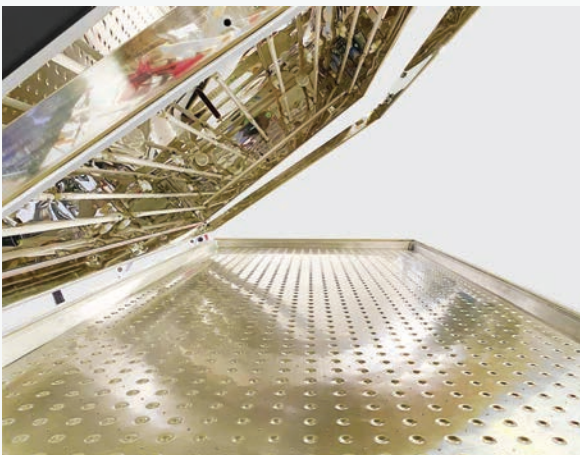

FULL PROCESS AREA ACCESS

Designed so nothing gets in the way of pressing.

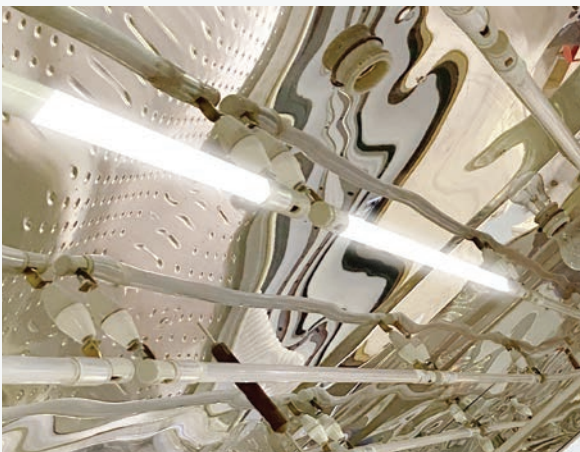

EASY TO MAINTAIN

With independent, interchangeable heating lamps that are easy to replace.

TECHNICAL SPECS

Process Area	48" x 96", customizable
Voltage	208-240 volts, 3-phase + common, 60amp
Air	8 bar, 9 cfm, 120 psi
Heating Lamps	800W per lamp, total of 13.6W
Vacuum Pump	2.2KW. Pressure of -0.08Mpa

FOOTPRINT

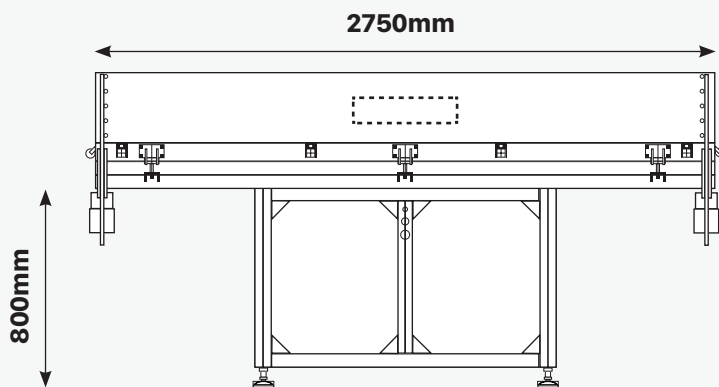

Front Elevation

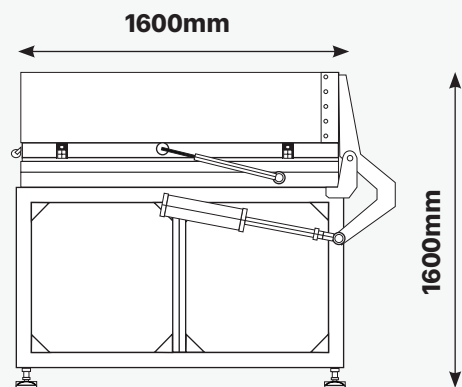

Right Side Elevation

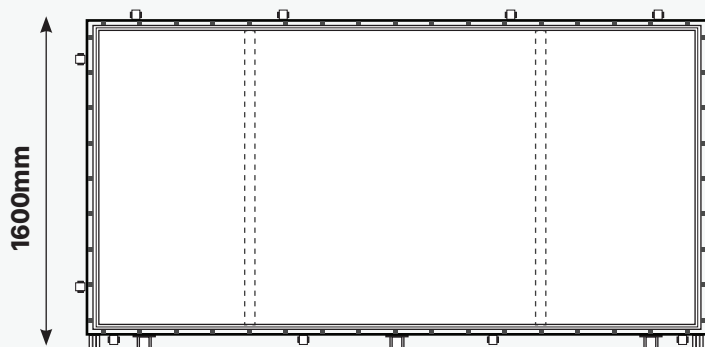

Top View



TERMS AND INSTALLATION

Terms of Payment

Terms of payment offered, or any terms agreed upon, are subject to credit approval if needed. This offer is subject to CNC Factory General Terms and Conditions of Sale. This order is subject to prior purchase of the equipment. Price quoted is for the machine as described above and is subject to change with notice or if the specifications for the machine are changed at the request of the buyer.

Shipment

Shipment is subject to delay should changes be made to meet the requirements of the purchaser from CNC Factory's design specification stated herein.

Training, Support and Conditions

Training, on machine operations only, can be done virtually or through the CNC Factory University training services.

CNC Factory is committed to maximizing your production time. Your machine may contain built-in safety/operational messages. You can contact CNC Factory Support Department at 714-581-5999 if you receive a machine message.

Warranty and Support

CNC Factory is proud to give you a 2 years of machine support and warrants the machinery will be free of defects in workmanship and materials for a period of 18 months beginning on the date of delivery. This warranty does not include parts consumed during normal operation (wearable) or maintenance required in the ordinary course of operation.